

# DA22XLR-WP-US-V2

## Quick Reference Guide

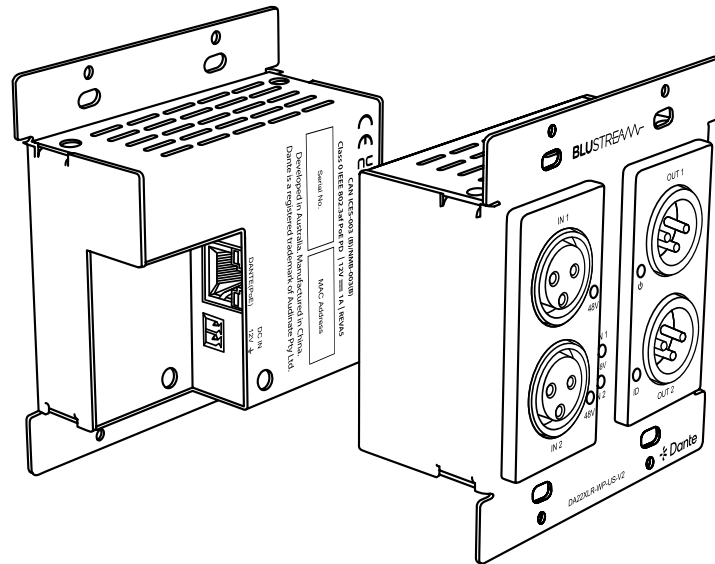

## Introduction

The DA22XLR-WP is a multi-input / output wall plate to convert analog audio within a digital Dante® networked audio system. The DA22XLR-WP converts 2 input channels of balanced / unbalanced / MIC audio with switchable 48v Phantom power to Dante® digital audio, and 2 channels of Dante® audio to 2 output channels of balanced / unbalanced audio.

The DA22XLR-WP is a plug & play device that is powered using PoE (Power over Ethernet), or via 12v power supply, offers support for AES67 RTP audio transport and magnetic faceplate design allows installation into standard dual Decora US junction boxes. The DA22XLR-WP is the ideal BYOD interface to a Dante® audio system.

### FEATURES:

- Dante® network wall plate interface for 2 x audio inputs and 2 x audio outputs
- Converts 2 x balanced / unbalanced / MIC audio sources to Dante® audio channels
- Converts 2 x Dante® audio channels to balanced / unbalanced audio outputs
- Switchable 48V Phantom power for each MIC XLR input
- Adjustable MIC / line sensitivity from +24dBu to -28dBV for each XLR input
- Adjustable line gain from +20 dBu to -28 dBV for each XLR output
- Supports: 44.1, 48, 88.2 & 96kHz sample rates @ 16, 24 or 32 Bit
- Configurable Dante® device latency (supports 2, 3, 4, 5 or 10ms configurable using Dante® Controller)
- Supports AES67 RTP audio transport
- Features Class 0 IEEE 802.3af PoE for powering of product from any PoE switch
- Supports power via 12V DC adapter (not included) for when network switch does not support PoE
- White magnetic faceplate surround and US Decora style backbox compatibility
- In-built web-GUI for configuration and control

# Dante Controller

Dante Controller software is required in order to setup and configure the DA22XLR-WP-US-V2 as well as control your Dante network. Audinate provide extensive training videos and documentation on their website. This can be found here: <http://www.audinate.com/products/software/dante-controller>

Upon connecting your DA22XLR-WP-US-V2 to a compatible network, the Dante Controller software should automatically discover the device. The DA22XLR-WP-US-V2 will appear in the Dante Controller with a name denoted with “DA22XLR-WP-US-V2”. On the “Routing” screen you can create audio routing between Dante transmitters and receivers in your system.

Please ensure your PC is on the same network as your Dante devices. Dante is not able to transmit over WiFi and it is recommended to hardwire into the Dante network. Having multiple network devices enabled can also confuse the Dante Controller software so it is recommended to disable WiFi during configuration.

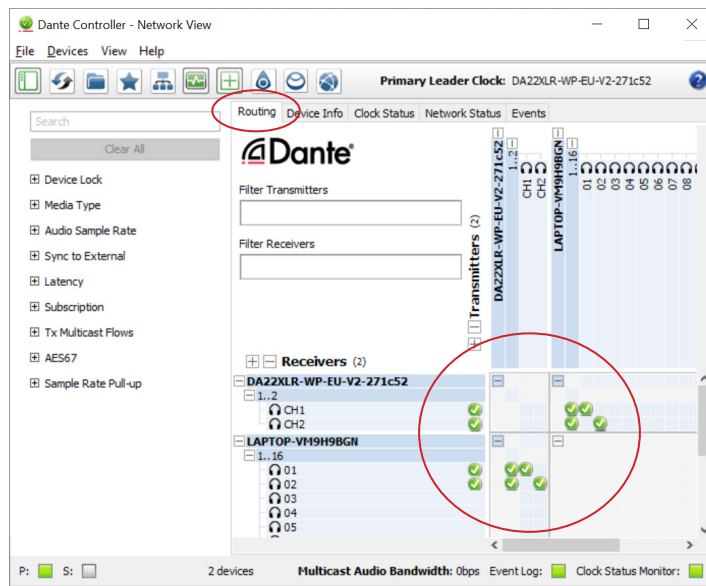

It is also possible to change the settings of the DA22XLR-WP-US-V2 under the “Device Info” screen in the Dante Controller software. To do so, select the “Device Config” menu.

Here we can adjust the sample rate and the encoding bit rate of the DA22XLR-WP-US-V2. Please note that Dante products can only transmit or receive audio from other Dante products that are set up with the same sample rate. A mismatch in sample rate may stop audio from transmitting.

Under the “Device Config” screen we can also adjust the latency of the DA22XLR-WP-US-V2 from 2, 3, 4, 5 or 10 milliseconds.

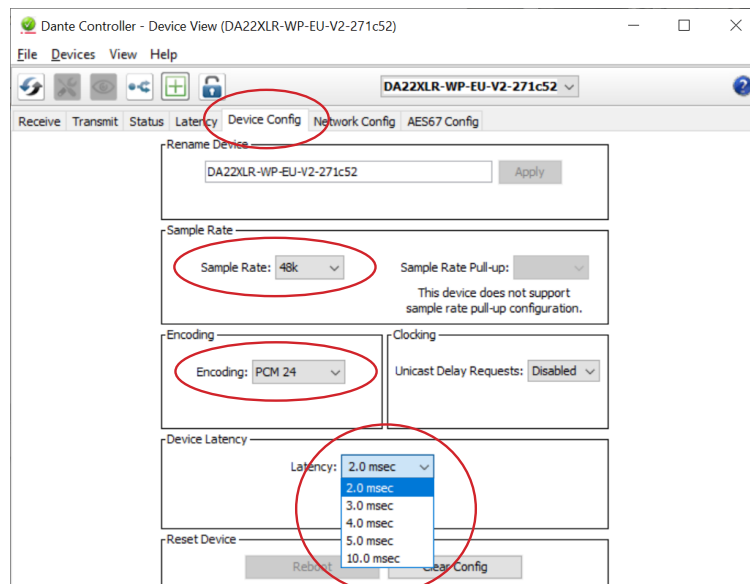

# Web Interface Module

The DA22XLR-WP-US-V2 features an in-built Web GUI which can be used for control and configuration of the device. By default the device is set to DHCP, however if a DHCP server (eg: network router) is not installed the device will receive a link local address in the 169.254.xxx.xxx range. The device info screen of Dante Controller will provide you with the IP address information of each unit.

Device Name	Model Name	Product Version	Dante Version	Device Lock	Primary Address	Primary Link Speed	Secondary Address	Secondary Link Speed
DA22XLR-WP-EU-V2-271c52	DA22XLR-WP-EU-V2	1.0.1	1.3.1.1	<input type="checkbox"/>	169.254.92.193	100Mbps	N/A	N/A
LAPTOP-VM9H9BGN	Dante Virtual Soundcard	4.4.1.3	4.4.1.3	<input type="checkbox"/>	169.254.0.222	1Gbps	N/A	N/A

By accessing the IP address of the DA22XLR-WP-US-V2 in your web browser, you will gain access the units web GUI. The following details will allow you to log in to the admin section:

Default **Username** is: [blustream](#)      Default **Password** is: [1234](#)

This will give access to change the network settings as required, as well as configure the device.

### Settings Page:

## Settings

Control
Users
Settings
System
Information
Update Password
Log Out

### IP Setting

IP Mode: Static DHCP

IP Address:

Subnet:

TCP Port:   Enable

Gateway:

Telnet Port:   Enable

Domain Name:  .local

### Product Model Setting

Product Model:

Set Network Defaults
Save

## Panel Description

### Connections:

- 1 Analogue Audio Input - XLR connector for balanced or unbalanced analogue audio input
- 2 48V Phantom Power Indicator- Illuminates when 48V phantom power is enabled
- 3 48V Phantom Power Switch - Press to enable/disable 48V phantom power for microphones on corresponding input
- 4 Analogue Audio Output - XLR connector for balanced or unbalanced analogue audio output
- 5 Power Status Indicator - Illuminates when the device is powered on power input
- 6 ID LED Indicator - Flashes when this device is identified through Dante® Configurator
- 7 Dante® Network Connection (PoE) - RJ45 connection to connect to network switch
- 8 Power Port – Use 12V/1A DC adaptor (not included) when PoE is not available to power device

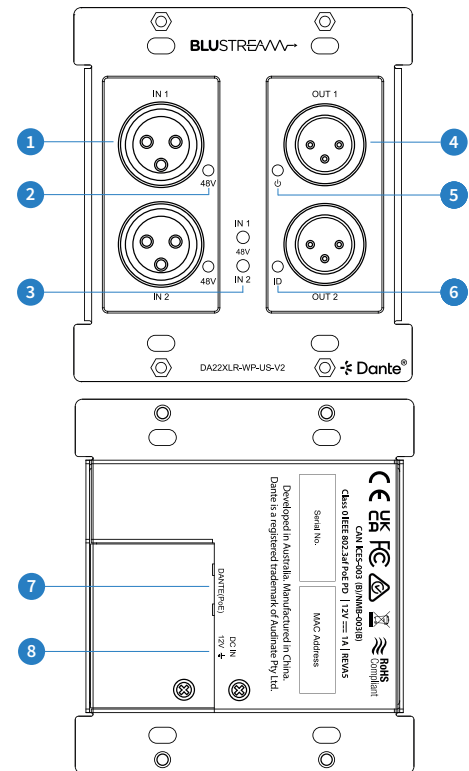

## Specifications

**Audio Input Connectors:** 2 x Analogue balanced/unbalanced 3-Pin XLR connector

**Audio Output Connectors:** 2 x Analogue balanced/unbalanced 3-Pin XLR connector

**Network Connectors:** 1 x PoE Dante® Ethernet Connection (RJ45)

**Configuration Switches:** 2 x Push button (48V Phantom power)

**Firmware Upgrade:** 1 x Micro-USB port

**Module Dimensions (L x W x H):** 105mm x 95mm x 45mm (without faceplate)

**Faceplate Dimensions (L x W x H):** 115mm x 115mm x 5mm

**Cut Out Dimensions (L x W x H):** 89mm x 71mm x 41mm

**Mounting Hole Spacing:** US 83.5mm CTC

**Backbox Requirements:** US double gang junction box

**Shipping Weight:** 0.6kg

**Operating Temperature:** 32°F to 104°F (0°C to 40°C)

**Storage Temperature:** - 4°F to 140°F (- 20°C to 60°C)

**Power Supply:** Class 0 IEEE 802.3af POE PD or 12V/1A DC, 2-Pin Phoenix connector

## Package Contents

- 1 x DA22XLR-WP-US-V2
- 1 x Magnetic Faceplate
- 1 x Quick Reference Guide

## Acknowledgements

Dante® is a registered trademark of Audinate Pty Ltd.

## Certifications

### FCC NOTICE

This equipment has been tested and found to comply with the limits for a Class B digital device, pursuant to part 15 of the FCC Rules. These limits are designed to provide reasonable protection against harmful interference in a residential installation. This equipment generates, uses, and can radiate radio frequency energy and, if not installed and used in accordance with the instructions, may cause harmful interference to radio communications. However, there is no guarantee that interference will not occur in a particular installation. If this equipment does cause harmful interference to radio or television reception, which can be determined by turning the equipment off and on, the user is encouraged to try to correct the interference by one or more of the following measures:

- Reorient or relocate the receiving antenna.
- Increase the separation between the equipment and receiver.
- Connect the equipment into an outlet on a circuit different from that to which the receiver is connected.
- Consult the dealer or an experienced radio/TV technician for help.

**CAUTION** - changes or modifications not expressly approved by the party responsible for compliance could void the user's authority to operate the equipment.

### CANADA, INDUSTRY CANADA (IC) NOTICES

This Class B digital apparatus complies with Canadian ICES-003. Operation is subject to the following two conditions: (1) this device may not cause interference, and (2) this device must accept any interference, including interference that may cause undesired operation of the device.

### CORRECT DISPOSAL OF THIS PRODUCT

This marking indicates that this product should not be disposed with other household wastes. To prevent possible harm to the environment or human health from uncontrolled waste disposal, recycle it responsibly to promote the sustainable reuse of material resources. To return your used device, please use the return and collection systems or contact the retailer where the product was purchased. They can take this product for environmentally safe recycling.